

UNIVERSAL

Pre-installation reversible embedded box for masonry

APPLICATION

Set-up for electric cables, refrigeration pipes, and for condensation drain and air-conditioning units for masonry.

FEATURES AND BENEFITS

- > It is designed with **shockproof material and internal ribs** which make it more stiff.
- > It is provided with **8 entries for cooling lines**, 4 of them on the sides, and the other 4 entries on the upper part of the box.
- > Its **inclined base** - left-right reversible - makes condensation water drainage easier, and it is provided with **a lateral outlet with a diameter of 16-20mm**.
- > **485 mm** long.
- > In its upper part the item is provided with a **slot that is specifically designed for the electric cable**, so that it keeps apart from the most damp area of the box (which includes cooling pipes and the area for the condensation water drainage).
- > It is provided **complete with**: O-RING washers, stiff cover and fixing screws.

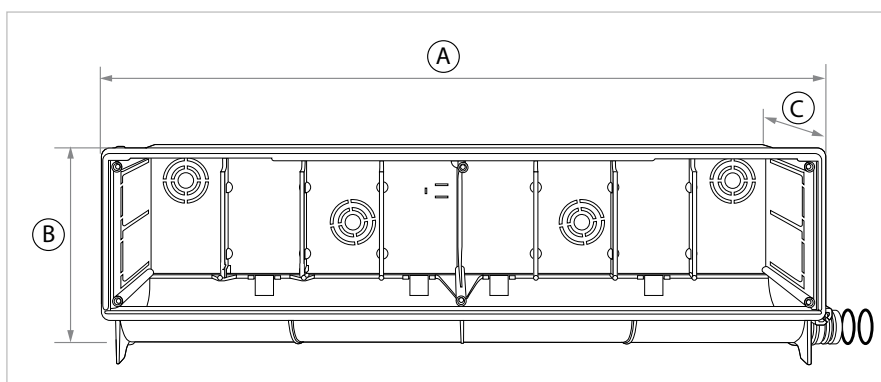
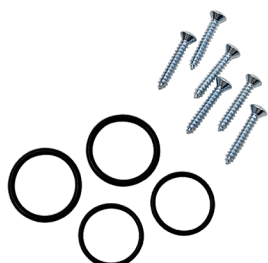

COD	TYPE	Application	A	B	C
520004	UNIVERSAL	Air-conditioner set-up	485	125	60

COMPONENTS FOR AIR-CONDITIONING

PRE-INSTALLATION EMBEDDED BOXES

MATERIALS TECHNICAL DATA

BOX

Shockproof styrofoam PS SR 550

SCREWS

Steel 4.8 EN ISO 898.1 with electro zinc-plating 7-8 µm

O-RING

Black NBR rubber

REDUCTION SOCKET

EP 440 G

WORKING TEMPERATURES

-10°C / +70°C

INSTALLATION

1. Determine the inlet of the refrigeration pipes, the power supply, and the draining pipe outlet.
2. Insert the refrigeration pipes and the electric cables (the refrigeration pipes inlet is usually on the left).
3. Apply the O-Ring washers and fasten the box to the wall.
4. Connect the box's tank to the condensate drip pipe.
5. Carry out the draining test and close the front side with the removable protective cardboard in order to prevent the entry of masonry debris, mortar of cement, and so on.

NB: In order to make it work properly, fasten the housing using a level. While, to obtain a good seal, make sure that the pipes - used to connect the draining pipe outlet - are clean.

PACKAGING

In cardboard box

DATE 07-2023 REV. 00

The current technical data sheet substitutes and cancels the previous ones. The details provided fit our current knowledge of the product. It cannot lead us to any sort of responsibility or compensation.

Gia S.p.A. reserves the right of changing technical features and molds without notice.

This company is subject to "Ethica Global Investments S.p.A." management.

Gia S.p.A. – Via Sac. A. Cremona, 12 – 28069 Trecate (NO) – www.gia.it