

RHINO Ground support for 41x41mm G-Strut channels

APPLICATION

Ground supports for air-conditioning outdoor units, heat pump, and small refrigerating systems.

FEATURES AND BENEFITS

- > Vibration-proof ground support made of **polypropylene reinforced with fibreglass**.
- > It is provided complete with a specific **base support for 41x41mm channel housing and positioning levels**.
- > Rhino is particularly **suited for supporting modular and adjustable structures** for condensing units belonging to large system, either on ground or roof.
- > Complete with a **NBR rubber mat - vibration-proof and skid-proof** - which makes the whole structure more stable and soundproof.
- > Working temperature: **-30°C / +75°C**

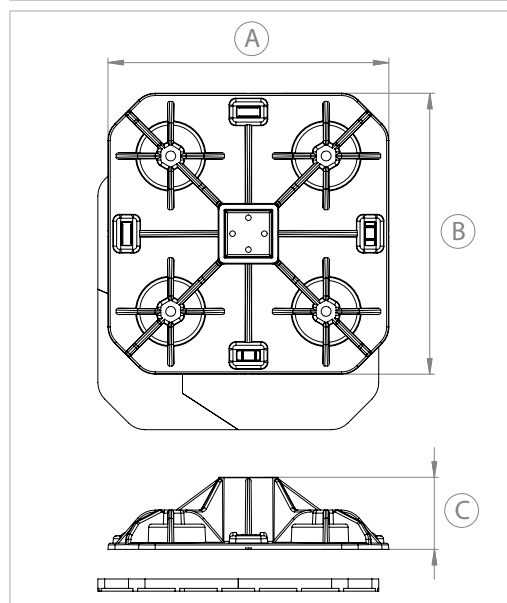

COD	TYPE	Colour	For channels	A	B	C
550135	RHINO	Black	41x41 mm	300	300	77

COMPONENTS FOR AIR-CONDITIONING GROUND SUPPORTS

Composed of:

- Polypropylene support
- Base support for 41x41mm channels housing
- Moulded mat

MATERIALS TECHNICAL DATA

SUPPORT

PP Polypropylene reinforced with fibreglass

BASE SUPPORT FOR CHANNELS

PP Polypropylene reinforced with fibreglass

MAT

NBR rubber

RECOMMENDED LOADS

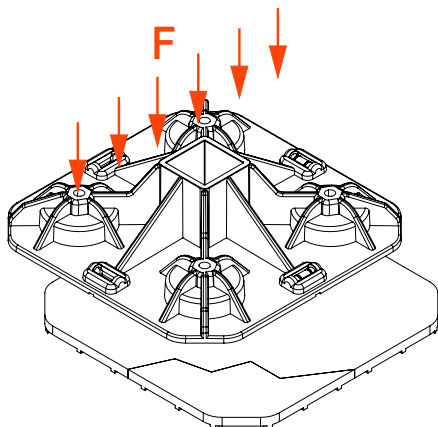

TYPE	F
RHINO	350

F = load evenly distributed (in Kg)

PACKAGING

In cardboard box

DATE 08-2023 REV. 00

The current technical data sheet substitutes and cancels the previous ones. The details provided fit our current knowledge of the product. It cannot lead us to any sort of responsibility or compensation.

Gia S.p.A. reserves the right of changing technical features and molds without notice.

This company is subject to "Ethica Global Investments S.p.A." management.

Gia S.p.A. – Via Sac. A. Cremona, 12 – 28069 Trecate (NO) – www.gia.it