

PDN Square-based polypropylene ground support

APPLICATION

Ground supports for air-conditioning outdoor units.

FEATURES AND BENEFITS

- > Ground supports with square base, made of **shock-proof UV stabilized polypropylene**.
- > Designed with a fixed height of **90mm**, they are provided **complete with M8 nuts and bolts** for the unit's fastening.
- > They are also provided with an **O-ring washer** that must be set inside the rail underneath the base, in order to reduce vibrations and better hold the support down to the ground.

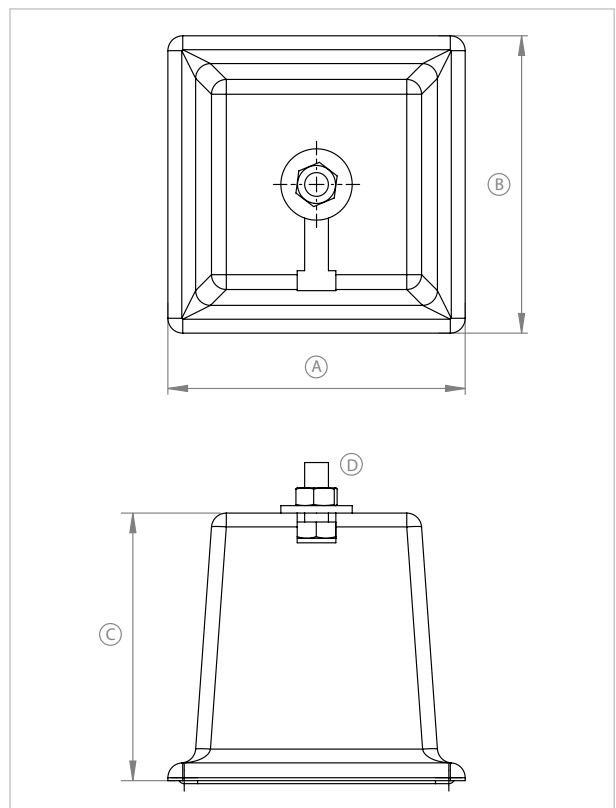

COD	TYPE	Colour	A	B	C	D
550101	PDN W	Ivory	100	100	90	M8
550102	PDN B	Black	100	100	90	M8

COMPONENTS FOR AIR-CONDITIONING

GROUND SUPPORTS

Composed of:

- Polypropylene square-based support
- Fixing kit: M8 bolt, M8 washer, M8 hammer-head nut
- O-ring sheath

MATERIALS TECHNICAL DATA

SUPPORT

PP Polypropylene - Ivory or black

FIXING KIT

Steel 4.8 DIN 933-8.8 with electro zinc-plating 7-8 μm EN ISO 12329

RECOMMENDED LOADS

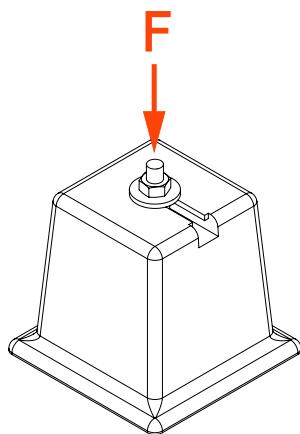

TYPE	F
PDN W	100
PDN B	100

F = concentrated load (in Kg)

PACKAGING

In cardboard box

DATE 08-2023 REV. 00

The current technical data sheet substitutes and cancels the previous ones. The details provided fit our current knowledge of the product. It cannot lead us to any sort of responsibility or compensation.

Gia S.p.A. reserves the right of changing technical features and molds without notice.

This company is subject to "Ethica Global Investments S.p.A." management.

Gia S.p.A. – Via Sac. A. Cremona, 12 – 28069 Trecate (NO) – www.gia.it