

KONG R Ø100 mm Adjustable ground support with screw

APPLICATION

Ground supports for air-conditioning outdoor units or boilers.

FEATURES AND BENEFITS

- > Ground support made of **polypropylene reinforced with fibreglass**.
- > **Highly resistant** to bad weather conditions, and **UV stabilized**.
- > **Adjustable height from 120 mm up to 180mm**, thanks to a specific ferrule.
- > Complete with **M10 nut and bolt** for the unit's fastening.
- > It is provided with an **upper junction**, which makes it able to fit the slope of the ground.
- > It is also equipped with **two NBR rubber seals**: one of them is set at the top - on the upper junction - to absorb vibrations; the other one is set at the bottom in order to make the support more stable, while preventing sliding and vibration spread as well.
- > It is available in two different colours: **black and ivory**.
- > Working temperature: **-30°C / +75°C**

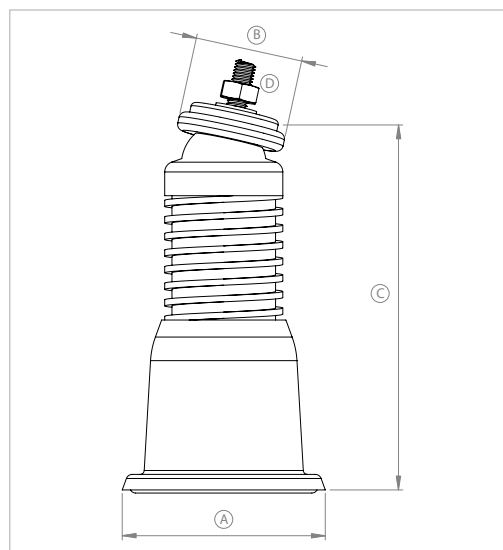

COD	TYPE	Colour	A	B	C	D
550111	KONG WR	Ivory	Ø100	Ø50	120-180	M10
550112	KONG BR	Black	Ø100	Ø50	120-180	M10

COMPONENTS FOR AIR-CONDITIONING

GROUND SUPPORTS

Composed of:

- Polypropylene support
- Fixing kit: M10 bolt, M10 washer, M10 hammer-head nut
- 2 O-ring seals

MATERIALS TECHNICAL DATA

SUPPORT

PP Polypropylene reinforced with fibreglass - Ivory or black

FIXING

Steel 4.8 DIN 933-8.8 with electro zinc-plating 7-8 μm EN ISO 12329

SEALS

NBR rubber

RECOMMENDED LOADS

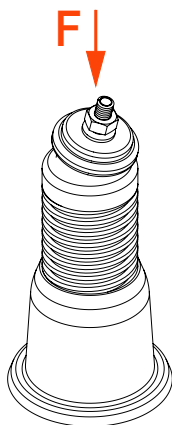

TIPO	F
KONG WR	150
KONG BR	150

F = concentrated load (in Kg)

PACKAGING

In cardboard box

DATE 08-2023 REV. 00

The current technical data sheet substitutes and cancels the previous ones. The details provided fit our current knowledge of the product. It cannot lead us to any sort of responsibility or compensation.

Gia S.p.A. reserves the right of changing technical features and molds without notice.

This company is subject to "Ethica Global Investments S.p.A." management.

Gia S.p.A. – Via Sac. A. Cremona, 12 – 28069 Trecate (NO) – www.gia.it