

KAMEL Polypropylene ground supports

APPLICATION

Ground supports for air-conditioning outdoor units.

FEATURES AND BENEFITS

- > Ground supports made of **shock-proof UV stabilized polypropylene**.
- > They guarantee a **solid and long lasting fixing**, as well as a good looking result.
- > **Complete with M8 nuts and bolts** for the outdoor unit's fastening.
- > They are available in two sizes - **450 and 520 mm long** - both grey.
- > Working temperature: **-30°C / +75°C**

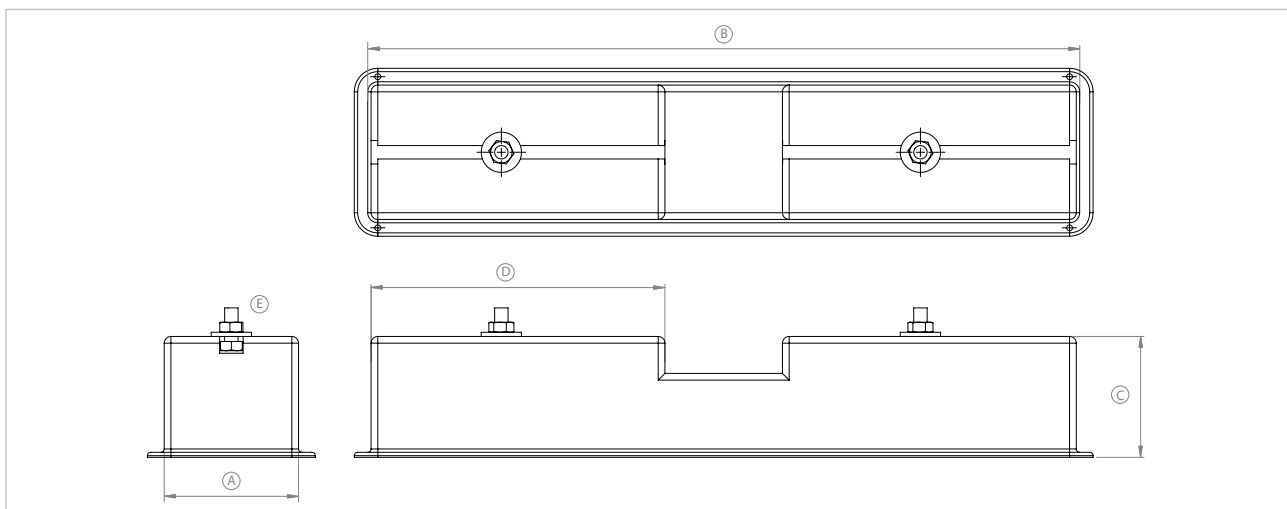

COD	TYPE	Colour	A	B	C	D	E
550050	KAMEL 420	Grey	90	420	72	175	M8
550051	KAMEL 520	Grey	90	520	72	225	M8

COMPONENTS FOR AIR-CONDITIONING GROUND SUPPORTS

Composed of:

- Polypropylene moulded base support
- Fixing kit: 4 M8 bolts, 4 M8 washers, 4 M8 hammer-head nuts
- Adhesive strips

MATERIALS TECHNICAL DATA

SUPPORT

PP Polypropylene - Grey

FIXING KIT

Steel 4.8 DIN 933-8.8 with electro zinc-plating 7-8 μm EN ISO 12329

RECOMMENDED LOADS

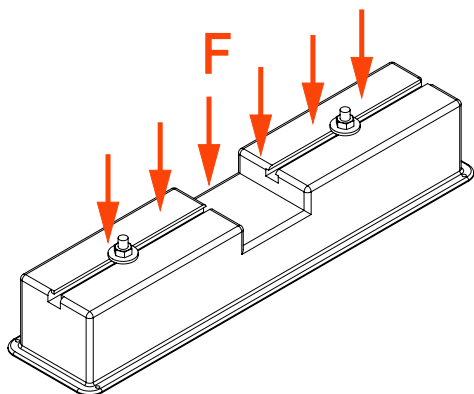

TYPE	F
KAMEL 420	120
KAMEL 520	120

F = load evenly distributed (in Kg)

PACKAGING

In cardboard box

DATE 08-2023 REV. 00

The current technical data sheet substitutes and cancels the previous ones. The details provided fit our current knowledge of the product. It cannot lead us to any sort of responsibility or compensation.

Gia S.p.A. reserves the right of changing technical features and molds without notice.

This company is subject to "Ethica Global Investments S.p.A." management.

Gia S.p.A. – Via Sac. A. Cremona, 12 – 28069 Trecate (NO) – www.gia.it