

BP1-BP2

Pair of 450/350 mm ground supports

APPLICATION

Ground supports for outdoor units, provided with vibration-proof adhesive strips.

FEATURES AND BENEFITS

- > Base supports for floor installations, which are made of **shock-proof ivory PVC**.
- > Solid and **resistant to high temperatures and UV rays**.
- > Complete with **M10 nuts and bolts**, which are to be set in the moulded rail to fasten the outdoor unit.
- > Provided with **rubber adhesive strips**, which help **reducing vibration**.
- > Working temperatures: **-30°C / +75°C**

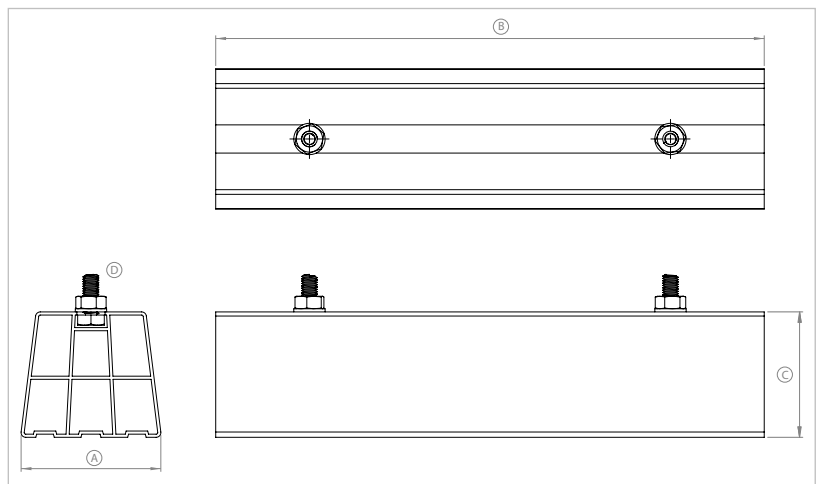
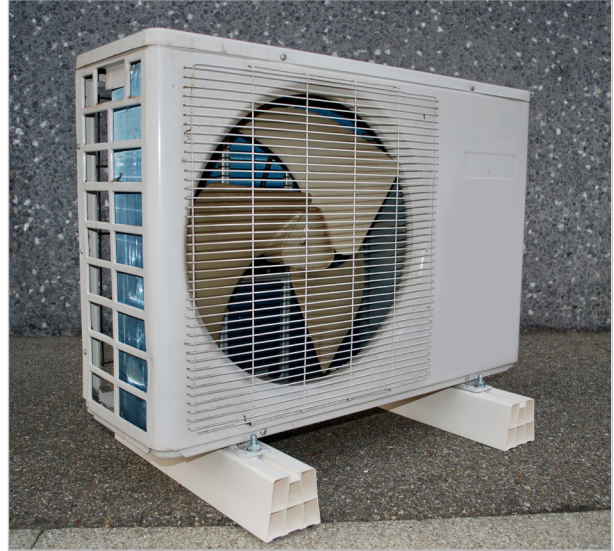

COD	TYPE	Colour	A	B	C	D
550022	BP1 80	Ivory	90	450	80	M10
550021	BP2 80	Ivory	90	350	80	M10
550032	BP1 100	Ivory	100	450	100	M10
550031	BP2 100	Ivory	100	350	100	M10

COMPONENTS FOR AIR-CONDITIONING GROUND SUPPORTS

Composed of:

- PVC moulded base support
- Fixing kit: 4 M10 bolts, 4 M10 washers, 4 M10 hammer-head nuts
- Adhesive strips

MATERIALS TECHNICAL DATA

SUPPORT

PVC Ivory

ADHESIVE STRIPS

ARMAFLEX rubber

FIXING KIT

Steel 4.8 DIN 933-8.8 with electro zinc-plating 7-8 μm EN ISO 12329

RECOMMENDED LOADS

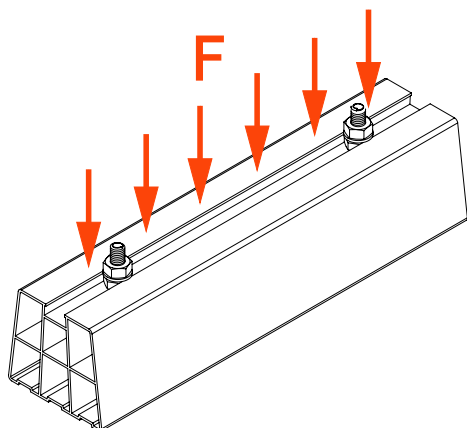

TYPE	F
BP1 80	140
BP2 80	140
BP1 100	160
BP2 100	160

F = load evenly distributed (in Kg)

PACKAGING

In cardboard box

DATE 08-2023 REV. 00

The current technical data sheet substitutes and cancels the previous ones. The details provided fit our current knowledge of the product. It cannot lead us to any sort of responsibility or compensation.

Gia S.p.A. reserves the right of changing technical features and molds without notice.

This company is subject to "Ethica Global Investments S.p.A." management.

Gia S.p.A. – Via Sac. A. Cremona, 12 – 28069 Trecate (NO) – www.gia.it